



User Guide in your own language

For more detailed information about the processes shown in this guide, read the User Guide.

Unboxing video



Unboxing
Watch our video to see how to correctly unbox.

Set up video



Install printing surface
Watch our video to see how to correctly position the printing surface.

Quick Start Guide

BCN3D Sigma Series

We would like to thank all users for trusting BCN3D, for helping us to reach our dreams and to create a better product every day.

1. Unboxing

The printer is heavy and therefore this step needs to be performed by two people. Make sure that the table where the printer is being installed, is close enough.

 Retain packaging for warranty service.

 Proper area to take out the printer with your hands.

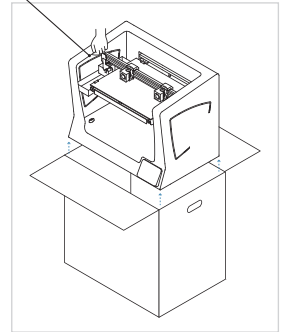
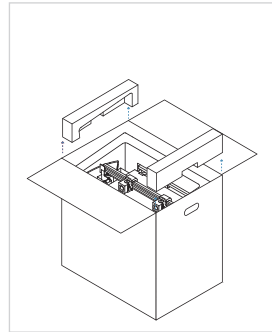
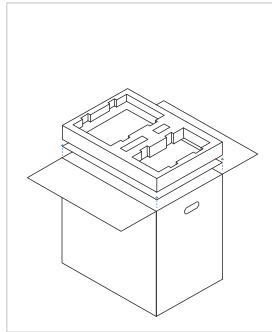

1. Open the box from the top.
2. Remove the components from the foam and place them on a table. Then remove the foam and the cardboard.

3. Remove the lateral foam protections.

4. Lift the printer with care holding it from the side flanges and place it on the table.
5. Open the plastic bag containing the printer.

2. Set up

Remove protections

- Remove all the protection foams inside the printer. There are three on the carriage and one under the printing surface.

Install plastic covers

- Take the plastic covers and thumbscrews from the packaging.
- Peel off the protective films.
- Use the thumbscrews to install the plastic covers.

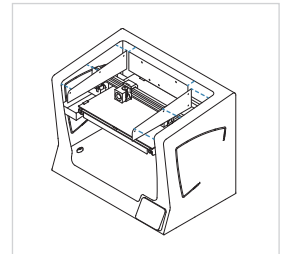
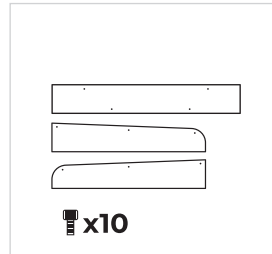
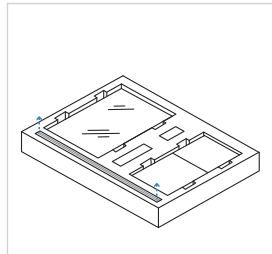

Install printing surface

- Pivot the left and right spring clips away from the aluminium platform.
- Take the glass printing surface from the upper protective foam.
- Place the glass printing surface on top of the aluminium platform.
- Insert the glass with light force into the back spring clips.
- Fix it with the left and right spring clips.

 The glass printing surface must be handled with care. In case of breakage, it may cause injuries.

3. Using the printer

The BCN3D Sigma Series can be used online or offline. However connecting the printer to the network is needed in order to register it and to use the BCN3D Cloud functionality.¹

Online

Ethernet

- Take the ethernet cable out from accessories box.
- Connect the ethernet cable to the ethernet port at the back of the printer.
- Connect the other end of the cable to a network source.

Wifi

- Find the USB WiFi Dongle in the accessories box.
- Plug the USB WiFi Dongle into the USB port at the back of the printer.

Offline

SD Card

- Find the SD Card in the tool box, inside the upper box.
- Insert the SD Card into the SD Card slot at the front of the printer.

Turn on the printer

- Take the power supply cable out from the accessories box that was on top of the printer.
- Connect the power supply cable to the power socket at the back of the printer.
- Plug the other end of the cable into a wall outlet.
- Turn the printer on. The power switch is found on the left side of the printer.

Getting started

Scan the QR code to be guided through the Setup Assistant for network connectivity, loading filament and calibrating your printer.

Diagram

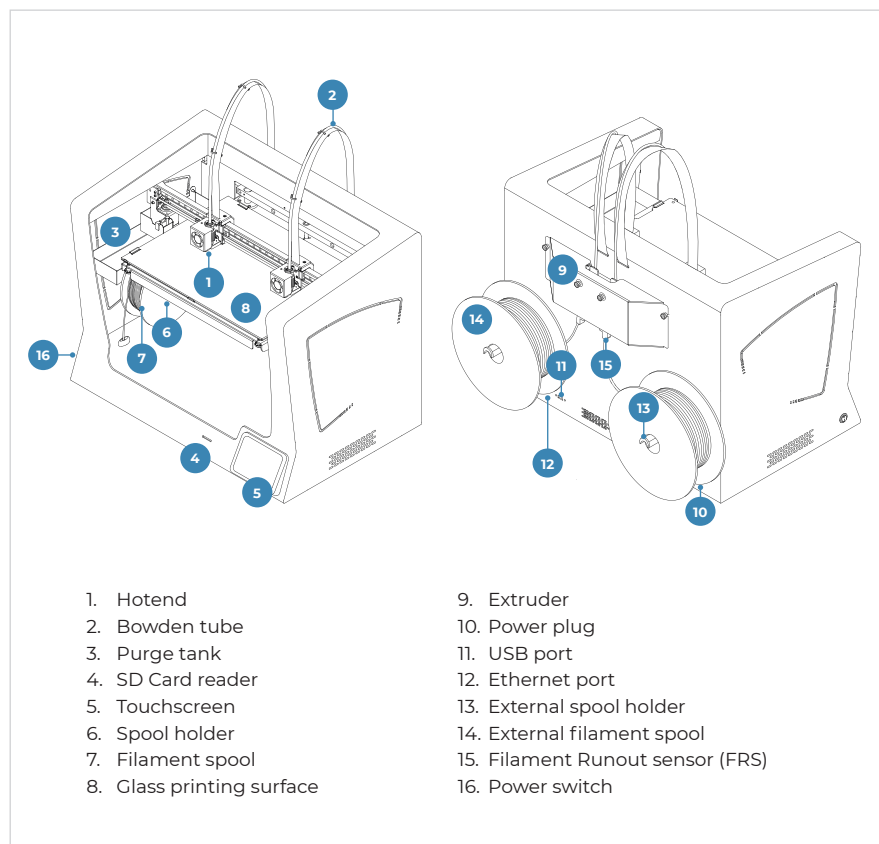

Information

¹If you have the option, we recommend using the printer with an Ethernet connection as it is more stable than Wifi.

Getting started



Setup Assistant
Watch our video to see how to run the Setup Assistant

What is in the box?

- BCN3D Sigma Series with 0.4mm hotends
- Glass printing surface
- 2 PLA spools
- 2 Spool holders
- Quick start guide
- SD card
- Ethernet cable
- USB cable
- Spatula
- 3 Allen key
- Pliers
- 10 Hotend Shims
- USB Wifi dongle
- Power supply cable
- Nylon cleaning filament
- Calibration gauge
- Magigoo glue stick
- Sample part
- 3 plastic covers
- 10 Thumbscrews



BCN3D Technical Assistance Services

If you do not find a solution to your problem in this manual, please contact the BCN3D technical support team through Contact Support.